

THE REPRODUCTION, DISTRIBUTION AND UTILIZATION OF THIS DOCUMENT AS WELL AS THE COMMUNICATION OF ITS CONTENTS TO OTHERS WITHOUT EXPLICIT AUTHORIZATION IS PROHIBITED. OFFENDERS WILL BE HELD LIABLE FOR THE PAYMENT OF DAMAGES. ALL RIGHT RESERVED IN THE EVENT OF THE GRANT OF A PATENT, UTILITY MODEL OR DESIGN. (PER ISO 18018)

REVISIONS

REV	DESCRIPTION	DATE	APPROVED
A	REDRAWN - SUPERSEDES 1GA_FJ_ SHEET 1/2, REV. NONE FOR 1GA6FJ4 (1)NOTE # 1(a) WAS: "CRIMP NUT PER ACES 2409P2"	3-20-95	EN-F15568 DP-24900

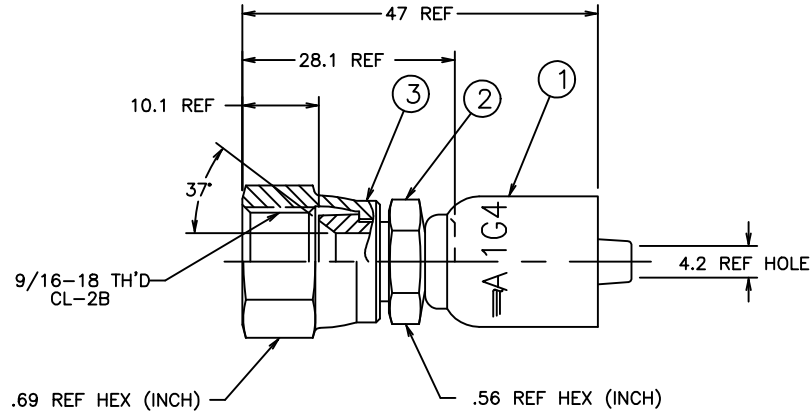

47	1.85
28.1	1.11
10.1	.40
4.2	.17
MM	INCH

CONVERSION

METRIC

1GA6FJ4	1G4	1F40000A0604-S	210204-6S
AEROQUIP PART NUMBER	① SOCKET	② NIPPLE	③ NUT
LIST OF MATERIALS			
ITEM NO.	MATERIAL	DRAWN J. HUFFMAN	
1	STEEL	CHECKED R. GARRETT	
2	STEEL	APPROVED R. GARRETT	
3	STEEL	RELEASE DATE 3-29-95	
		EN-F15568 DP-24900	
		SIZE C	DRAWING NUMBER 1GA6FJ4
		SCALE 2/1	DIST U
		CAGE CODE 01276	SHEET NO

2. 1SA6FJ4 NIPPLE ASSEMBLY MAY BE SUBSTITUTED FOR ITEMS #2 AND #3.

1. PROCESS AS FOLLOWS:
 (a) CRIMP NUT PER ACES 2813. ①
 (b) ASSEMBLE SOCKET PER ACES 2813.

CONVERTED DRAWING CADAM to AutoCAD 8/98

DWG. NO. 1GA6FJ4 SH. REV. A