

THE REPRODUCTION, DISTRIBUTION AND UTILIZATION OF THIS DOCUMENT AS WELL AS THE COMMUNICATION OF ITS CONTENTS TO OTHERS WITHOUT EXPLICIT AUTHORIZATION IS PROHIBITED. OFFENDERS WILL BE HELD LIABLE FOR THE PAYMENT OF DAMAGES. ALL RIGHT RESERVED IN THE EVENT OF THE GRANT OF A PATENT, UTILITY MODEL OR DESIGN. (PER ISO 18018)

REVISIONS

REV	DESCRIPTION	DATE	APPROVED
A	REDRAWN - SUPERSEDES 1GA_FJ_ SHEET 1/2, REV. NONE FOR 1GA5FJ6 (1)NOTE # 1(a) WAS: "CRIMP NUT PER ACES 2409P2"	3-20-95	EN-F15568 DP-24900

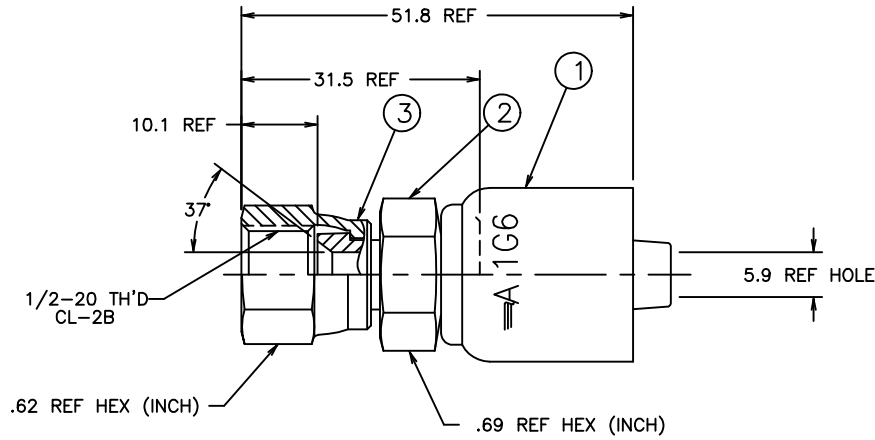

51.8	2.04
31.5	1.24
10.1	.40
5.9	.23
MM	INCH

CONVERSION

METRIC

1GA5FJ6	1G6	1F40000A0506-S	210204-5S		
AEROQUIP PART NUMBER	① SOCKET	② NIPPLE	③ NUT		
LIST OF MATERIALS					
ITEM NO.	MATERIAL	DRAWN J. HUFFMAN CHECKED R. GARRETT APPROVED R. GARRETT RELEASE DATE 3-29-95 EN-F15568 DP-24900 THIRD ANGLE PROJECTION			
1	STEEL	Garrett FLUID CONVEYANCE DIVISION DRAWING TITLE FITTING ASSEMBLY SAE 37° SWIVEL, OTC SIZE C DRAWING NUMBER 1GA5FJ6 REV A SCALE 2/1 DIST U CAGE CODE 01276 SHEET NO			
2	STEEL				
3	STEEL				

2. 1SA5FJ6 NIPPLE ASSEMBLY MAY BE SUBSTITUTED FOR ITEMS #2 AND #3.

1. PROCESS AS FOLLOWS:
 (a) CRIMP NUT PER ACES 2813. ①
 (b) ASSEMBLE SOCKET PER ACES 2813.

CONVERTED DRAWING CADAM to AutoCAD 8/98

DWG. NO. 1GA5FJ6 SH. REV. A