

THE REPRODUCTION, DISTRIBUTION AND UTILIZATION OF THIS DOCUMENT AS WELL AS THE COMMUNICATION OF ITS CONTENTS TO OTHERS WITHOUT EXPLICIT AUTHORIZATION IS PROHIBITED. OFFENDERS WILL BE HELD LIABLE FOR THE PAYMENT OF DAMAGES. ALL RIGHT RESERVED IN THE EVENT OF THE GRANT OF A PATENT, UTILITY MODEL OR DESIGN. (PER ISO 18018)

REVISIONS

REV	DESCRIPTION	DATE	APPROVED
B	REDRAWN - SUPERSEDES 1GA_FJ_ SHEET 2, REV "A" FOR 1GA12FJ10 (1)NOTE # 1(g) WAS: CRIMP NUT PER ACES 2409P2"	3-20-95	EN-F15568 DP-24900

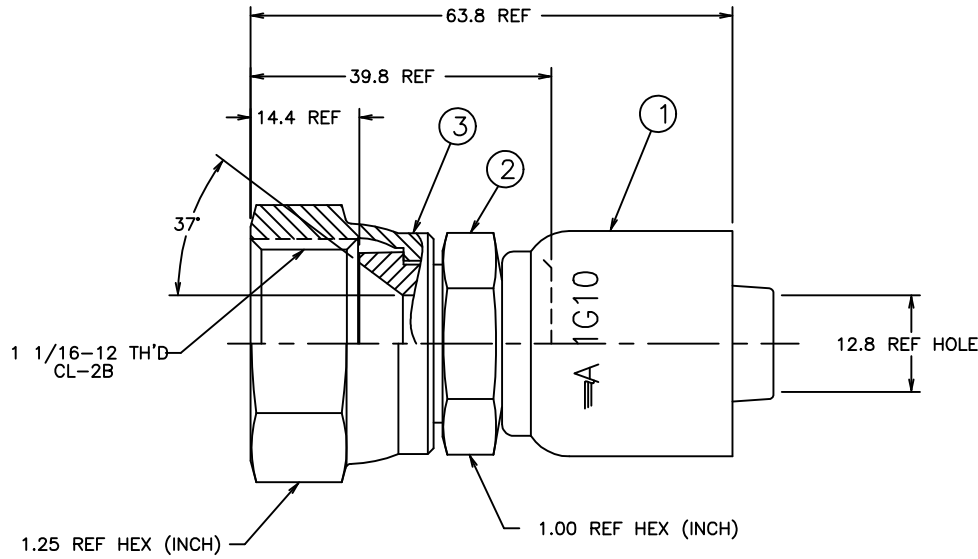

63.8	2.51
39.8	1.57
14.4	.57
12.8	.50
MM	INCH

CONVERSION

METRIC

ITEM NO.	MATERIAL	1GA12FJ10	1G10	1F40000A1210-S	210204-12S
		AEROQUIP PART NUMBER	SOCKET	NIPPLE	NUT
		①	②	③	
LIST OF MATERIALS					
		DRAWN J. HUFFMAN			
		CHECKED R. GARRETT			
		APPROVED R. GARRETT			
		RELEASE DATE 3-29-95			
		EN-F15568 DP-24900			
		SIZE C	DRAWING NUMBER 1GA12FJ10		REV B
		SCALE 2/1	DIST U	CAGE CODE 01276	SHEET NO

2. 1SA12FJ10 NIPPLE ASSEMBLY MAY BE SUBSTITUTED FOR ITEMS #2 AND #3.

1. PROCESS AS FOLLOWS:

- (a) CRIMP NUT PER ACES 2813.
- (b) ASSEMBLE SOCKET PER ACES 2813.

⑧

REV. B
SH.
1GA12FJ10
DWG. NO.

CONVERTED DRAWING CADAM to AutoCAD 8/98